



INSTALLATION

HYPERCHARGER AIR FILTER KIT

9873

PARTS INCLUDED

- 1 Chrome Hypercharger Assembly with Chrome Blood Groove Trap Door
- 1 Vacuum Adapter Kit for H-D '07-up XL:
 - 1 Delphi Fuel Injection Adapter
 - 1 Straight Barbed Fitting
 - 2 Breather Bolt Spacers
 - 1 Throttle Body Gasket
 - 2 M4 x .7 x 30mm Socket Head Cap Screw
- 1 Crankcase Breather Kit for Sportster
 - 1 Breather Adapter
 - 1 90-degree Elbow
 - 2 Straight Barbed Fittings—**ONE USED**
 - 1 5/32" Black Vacuum Line
 - 1 Barbed T Fitting
 - 3 1/4"-20 x 1-3/8" Socket Head Cap Screws
 - 1 Throttle Body Gasket with adhesive
 - 2 Throttle Body Gaskets
 - 4 4" black cable ties
- 2 Breather Hoses
- 2 Breather Bolts
- 1 Installation Instructions

Please read and understand entire instructions before starting installation.

THANK YOU FOR CHOOSING KÜRYAKYN!

IN ORDER TO PROTECT YOU AND OTHERS FROM POSSIBLE INJURY AND/OR PROPERTY DAMAGE OR LOSS, PLEASE PAY CLOSE ATTENTION TO ALL INSTRUCTIONS, WARNINGS, CAUTIONS AND NOTICES REGARDING THE USE AND CARE OF THIS PRODUCT.



THIS INDICATION ALERTS YOU TO THE FACT THAT IGNORING THE CONTENTS DESCRIBED HEREIN CAN RESULT IN POTENTIAL DEATH OR SERIOUS INJURY.



This indication alerts you to the fact that ignoring the contents described herein may negatively affect product performance and functionality.



IF INSTALLING THIS PRODUCT FOR ANOTHER PARTY, PLEASE MAKE SURE THEY RECEIVE THIS COPY OF THE INSTALLATION INSTRUCTIONS SO THEY ARE AWARE OF THE IMPORTANT INFORMATION CONTAINED IN THEM.

TOOLS SUGGESTED

Set of Hex Wrenches, Set of Combination Wrenches, Set of Torx Wrenches, Side Cutter

STRICTLY OBSERVE THE FOLLOWING GUIDELINES IN ORDER TO USE THE PRODUCT PROPERLY AND AVOID POTENTIALLY DANGEROUS ACCIDENTS.

STEP 1

Read and understand all steps in the instructions before starting the installation. Park the motorcycle on a hard, level surface and turn off the ignition. Let cool.



YOU WILL BE WORKING AROUND THE ENGINE AND EXHAUST SYSTEM DURING INSTALLATION. ENSURE THAT THE ENGINE AND EXHAUST SYSTEM HAVE FULLY COOLED TO PREVENT INJURY.

CUSTOMER SERVICE

877.370.3604 (toll free)

INSTALLATION QUESTIONS

techsupport@kuryakyn.com
or call 715.247.2983

LIMITED WARRANTY

Küryakyn warrants that any Küryakyn products sold hereunder, shall be free of defects in materials and workmanship for a period of one (1) year from the date of purchase by the consumer excepting the following provisions:

- Küryakyn shall have no obligation in the event the customer is unable to provide a receipt showing the date the customer purchased the product(s).
 - The product must be properly installed, maintained and operated under normal conditions.
- Küryakyn makes no warranty, expressed or implied, with respect to any gold plated products.
 - Küryakyn shall not be liable for any consequential and incidental damages, including labor and paint, resulting from failure of a Küryakyn product, failure to deliver, delay in delivery, delivery in nonconforming condition, or for any breach of contract or duty between Küryakyn and a customer.

• Küryakyn products are often intended for use in specific applications. Küryakyn makes no warranty if a Küryakyn product is used in applications other than intended.

• Küryakyn electrical products are warranted for one (1) year from the date of purchase by the consumer. L.E.D.'S contained in components of Küryakyn products will be warranted for defects in materials and workmanship for 3 years from the date of purchase where as all other components shall be warranted for one(1) year. This includes, but is not limited to; control modules, wiring, chrome & other components.

• Küryakyn makes no warranty of any kind in regard to other manufacturer's products distributed by Küryakyn. Küryakyn will pass on all warranties made by the manufacturer and where possible, will expedite the claim on behalf of the customer, but ultimately, responsibility for disposition of the warranty claim lies with the manufacturer.

ABOUT OUR CATALOG

For purchasing Küryakyn® products, you can receive a complete catalog free of charge.

Send the Proof-of-Purchase below with your address to: Küryakyn, P.O. Box 339, Somerset, WI 54025.

Please indicate either Accessories Catalog for Harley-Davidson® or GL & Metric Cruisers.

Be sure to ask your local dealer about other Küryakyn® products, the motorcycle parts and accessories designed for riders by riders.

©2005 Küryakyn USA® All Rights reserved.



kuryakyn.com



A FACTORY SERVICE MANUAL WILL BE HELPFUL IN PERFORMING THIS INSTALLATION. DO NOT ATTEMPT TO PERFORM THIS INSTALLATION IF YOU ARE NOT CONFIDENT IN YOUR ABILITY TO COMPLETE ALL OF THE STEPS IN THE PROCEDURE; CONSULT A TRAINED TECHNICIAN. IMPROPER INSTALLATION COULD RESULT IN SERIOUS INJURY OR DEATH.

NOTICE

Some of our high performance air cleaners extend beyond the stock/OEM unit to achieve smoother air flow and better performance. Riding position may be affected, so it is important to familiarize yourself with the new riding position.

NOTICE

Proper tuning is important. We recommend fuel injected bikes should be tuned with a TTS Master Tune tuning system (calibrations available at www.kuryakyn.com), or by an experienced tuner, on a dyno, with an exhaust gas analyzer. Lean conditions and/or retarded ignition timing will cause high exhaust temperatures and discolor chrome exhaust.

STEP 2

Remove the stock air cleaner assembly and the throttle body support bracket. PIC 1

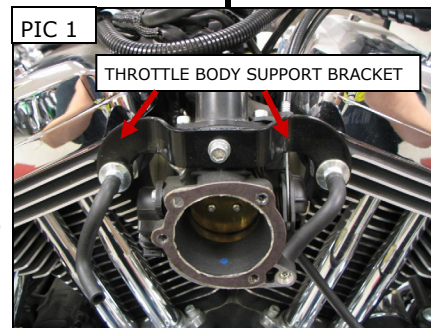

STEP 3

In order to gain better access for spacer installation, it is necessary to remove the gas tank. Be aware that some fuel may leak while disconnecting the pressure fitted fuel line. Remove the gas tank vent and electronic fuel pump wiring harness. The fuel line and gas tank vent is located on the left hand side, above the horn. The electronic fuel pump plug is located on the frame, directly above the inner primary case.

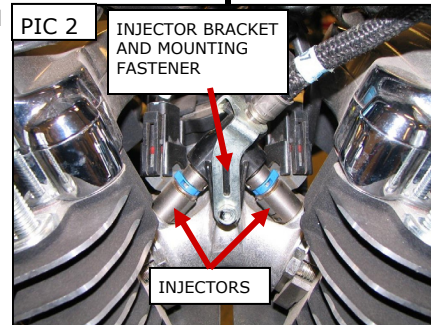

STEP 4

Unplug all previously mentioned connections and remove the gas tank. Set aside for reinstallation.

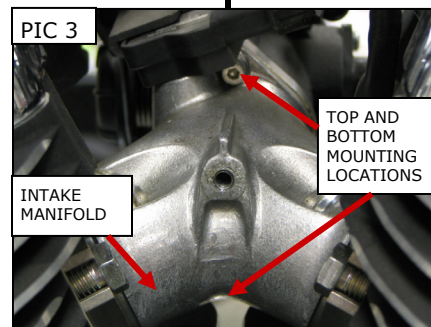

STEP 5

Unplug the wire leads from the backside of the horn. Remove the horn and horn bracket, exposing access to the injectors and intake screws which secure the throttle body. PIC 2

STEP 6

Remove the screw and bracket which secure the injectors to the backside of the intake, as shown in PIC 2. Carefully loosen and remove the injectors; lay them aside, noting the correct locations for proper reinstallation.

STEP 7

Loosen and remove the screws on the top and bottom of the intake, as shown in PIC 3. Be certain to secure the throttle body from falling, as these screws hold the throttle body to the intake.

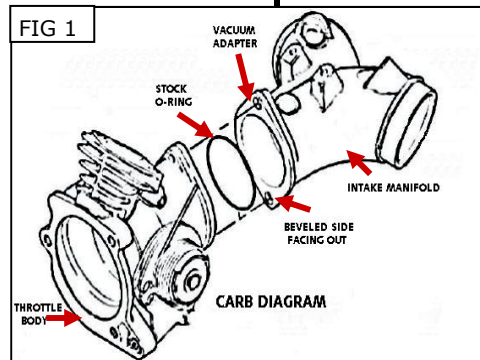

STEP 8

Separate the throttle body from the intake, noting the position of the stock O-ring. This O-ring will need to be reinstalled in the same position. See FIG 1 for proper O-ring positioning.

STEP 9

Place the new vacuum adapter gasket between the adapter and intake manifold. Thread the 3/16" barb fitting into the adapter, ensuring the fitment is snug. Do not over-tighten.

-cont.-

STEP 10 Test fit the vacuum adapter. The vacuum adapter should be installed so the vacuum fitting points down toward the front cylinder of the motorcycle. Wet the vacuum fitting with glass cleaner and slide the vacuum hose onto the fitting. The gasket side of the adapter will be installed facing the intake manifold. It is helpful to insert the top screw through the intake manifold to "hang" the adapter on. Be certain the stock O-ring is in place between the throttle body and the vacuum adapter, as shown in PIC 4. Using the supplied M4 x 30mm Socket Head Cap Screws, reattach the throttle body to the intake manifold, as it was removed in Step 7. Do not over-tighten.

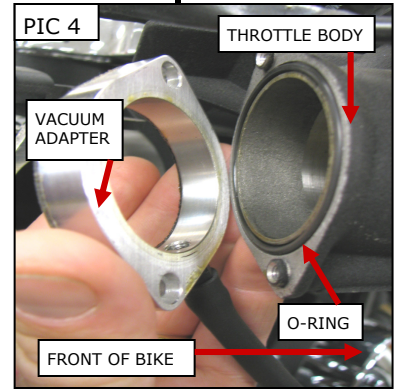

STEP 11 Place a small amount of grease on the O-rings located on the injectors. Reinstall the injectors into the manifold, as removed in Step 6. Reinstall the injector bracket.

STEP 12 Reinstall horn and horn bracket, reattach the wires on the back of the horn.

STEP 13 Loosely reinstall the throttle body support bracket to the throttle body only. Install the aluminum breather bolt spacer behind the support bracket. Place the provided breather bolts through the support bracket and aluminum spacers and into the heads. PIC 5 Secure all fasteners.

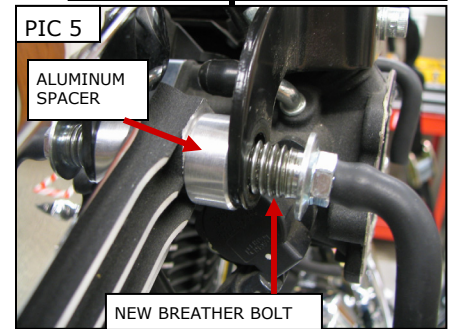

STEP 14 Remove the backing from the throttle body gasket and install on the face of the throttle body. Be certain the holes in the gasket line up with the holes in the throttle body.

STEP 15 Remove the three screws located on the face of the hypercharger. On the outer cover, remove the top and bottom screws that secure the butterfly caps. Remove the filter from the hypercharger and set aside. Remove the black plastic velocity ring.

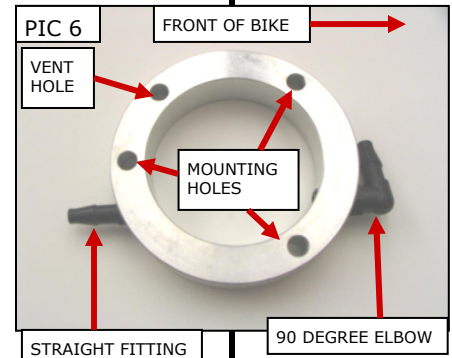

STEP 16 Insert the breather nipples into the crankcase breather. Note the right side (goes towards front of bike) fitting is the 90-degree elbow. PIC 6

STEP 17 Insert the three 1/4"-20 X 1-3/8" socket head cap screws through the mounting holes from the inside of the hypercharger. Place one of the remaining intake gaskets over the three mounting screws that protrude from the back of the hypercharger. Reference the mounting bolt locations shown in PIC 6. **DO NOT** place a bolt through the vent hole, located at the "10 o'clock" position on the crankcase breather.

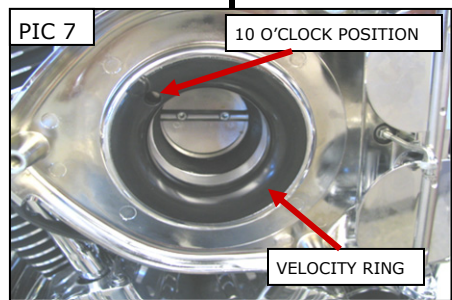

STEP 18 Slide the crankcase breather onto the protruding bolts on the back side of the hypercharger.

STEP 19 Attach the hypercharger backing plate, gasket and crankcase breather to the throttle body (with adhesive-backed gasket previously installed) with the included 1/4"-20" x 1-3/8" socket head cap screws with locking patch. Tighten the bolts evenly. **DO NOT** over-tighten. The bolts seat in the aluminum throttle body, and can easily become stripped or broken.

STEP 20 Connect the vacuum line with the newly installed vacuum adapter to the hypercharger vacuum nipple, located on the backside of the backing plate. This will allow the butterfly doors to move while the throttle is opened and closed.

- STEP 21** With the backing plate installed, snap the black velocity ring into the backing plate. Ensure that the hole in the velocity ring is in line with the remaining open vent hole ("10 o'clock" position) Be certain the velocity ring snaps securely in place before continuing the installation. PIC 7
- STEP 22** Place the air filter on the back plate. The filter fits around the raised lip on the inside of the back plate.
- STEP 23** Place the outer cover on the back plate. Reference Step 15 for reinstallation.
- STEP 24** Attach the breather hoses from the breather bolts to the crankcase breather nipples. Modifying or cutting the hoses may be necessary in order to ensure that kinks or tight bends do not limit/obstruct the air flow. On the right or front side, ensure there is no obstruction to the pull or return of the throttle wheel.
- STEP 25** Remount the gas tank. Reattach the fuel pump plug, gas vent, and fuel line from the throttle body to the gas tank. Application of a small amount grease to the fuel line will assist in mating the fuel line to the gas tank (the O-ring is located in the female coupler on the fuel tank)
- STEP 26** **Double check the tightness of all related fasteners, check for hose clearance and check throttle for correct operation, making sure it returns properly, before starting bike.**

WARNING ROTATE THROTTLE AND CHECK THAT IT MOVES FREELY AND RETURNS TO CLOSED BEFORE STARTING BIKE. FAILURE TO PROPERLY ADJUST THE THROTTLE CABLES COULD RESULT IN LOSS OF CONTROL CAUSING SERIOUS INJURY OR DEATH.

NOTICE It is the installer's responsibility to ensure that all of the fasteners (including pre-assembled) are tightened before operation of the motorcycle. Küryakyn will not provide warranty coverage on products or components lost due to improper installation or lack of maintenance. Periodic inspection and maintenance are required on all fasteners.

Ride On!