



# HONDA NC700X / NC750X HEATED

Comfort seat for NC700X (2012- and NC750X (2014-



- (E)** \*SHAD no se hará responsable de los daños causados por un incorrecto montaje y puesta a punto por un personal no cualificado.
- (GB)** \*SHAD will not hold responsibility for damages caused by an incorrect assembly or adjustment carried out by unqualified personnel.
- (F)** \*SHAD ne se portera pas responsable des dommages causés par un montage incorrect et mise au point par un personnel non qualifié.
- (D)** \*SHAD übernimmt nicht die Verantwortung für Schäden, die bei einer fehlerhaften Montage sowie einer Generalrevision durch nicht qualifiziertes Personal verursacht werden.
- (I)** \*SHAD non sarà responsabile dei danni causati da uno scorretto montaggio e/o da una messa a punto realizzata da personale non specializzato.
- (P)** \*A SHAD não se responsabiliza pelos danos causados devidos a uma montagem incorreta e feita por pessoas não qualificadas.

## COMPONENTES / PARTS / COMPOSANTS / EINZELBAUTEILE / COMPONENTI / COMPONENTES:



### TECHNICAL SPECIFICATIONS

Nominal voltage = 12 Vdc  
 Max. voltage = 15,5 Vdc  
 Min. Heating voltage = 11,3 Vdc  
 Min. non heating voltage = 8 Vdc  
 Consumption at 12 Vdc and 42°C = 1,2 ± 0,1 Amp  
 Consumption in Standby mode = 250 µAmp  
 Seat Hardware protection = IP68  
 Console protection = IP67  
 Working temperature range (-40 to 85°C)

- (E)** 1. Asiento calefactable.  
2. Consola calefacción.  
3. Sistema de cableado directa a batería.  
4. Sistema de cableado directo a llave.  
5. Bridas sujeción consola.
- (GB)** 1. Heated driver's seat  
2. Heating console  
3. Wiring system direct to battery  
4. Wiring system via key  
5. Console fixing Ties.
- (F)** 1. Siège conducteur chauffant  
2. Console chauffage  
3. Système de câblage direct sur la batterie  
4. Système de câblage direct sur la clé  
5. Brides de fixation console.
- (D)** 1. Beheizbarer Fahrersitz  
2. Heizkonsole  
3. Direkte Verkabelung mit der Batterie  
4. Direkte Verkabelung durch Schlüssel  
5. Konsolen-Befestigungsflansche
- (I)** 1. Sella conducente riscaldabile  
2. Piastra di riscaldamento  
3. Sistema di cablaggio diretto alla batteria  
4. Sistema di cablaggio diretto alla chiave  
5. Briglia di attacco alla piastra.
- (P)** 1. Suporte do condutor de aquecimento  
2. Painel de aquecimento  
3. Sistema de cablagem directa à bateria  
4. Sistema de cablagem directa à chave  
5. Flanges de fixação painel.

**MONTAJE / MOUNTING / MONTAGE/ MONTAGE / MONTAGGIO / MONTAGEM:**

**1.**

- Ⓔ Extraer los asientos originales
- ⒼⒸ Remove HONDA seats
- Ⓕ Enlever les selles d'origine
- Ⓓ Die originalen Sitzbänke herausnehmen
- Ⓘ Togliere le selle
- Ⓗ Extrair os assentos originais

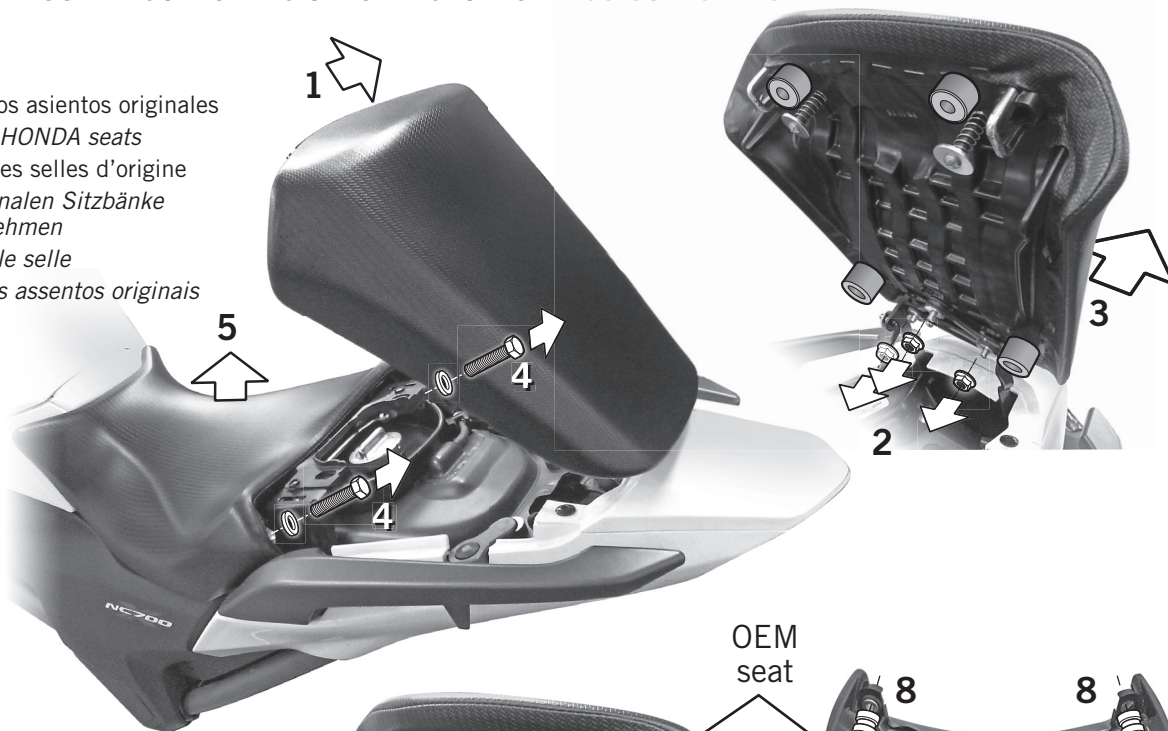

**2.**

- Ⓔ Cambiar las piezas de los asientos originales a los asientos SHAD STYLE
- ⒼⒸ Change pieces from Honda seat's to SHAD STYLE seat's
- Ⓕ Changer les pièces des selles d'origine aux selles SHAD STYLE
- Ⓓ Die Teile von den originalen Sitzbänken mit denen der SHAD STYLE Sitzbänke ersetzen
- Ⓘ Cambiare i pezzi dalle selle originali alle SHAD STYLE
- Ⓗ Trocar as peças dos assentos originais os assentos SHAD STYLE

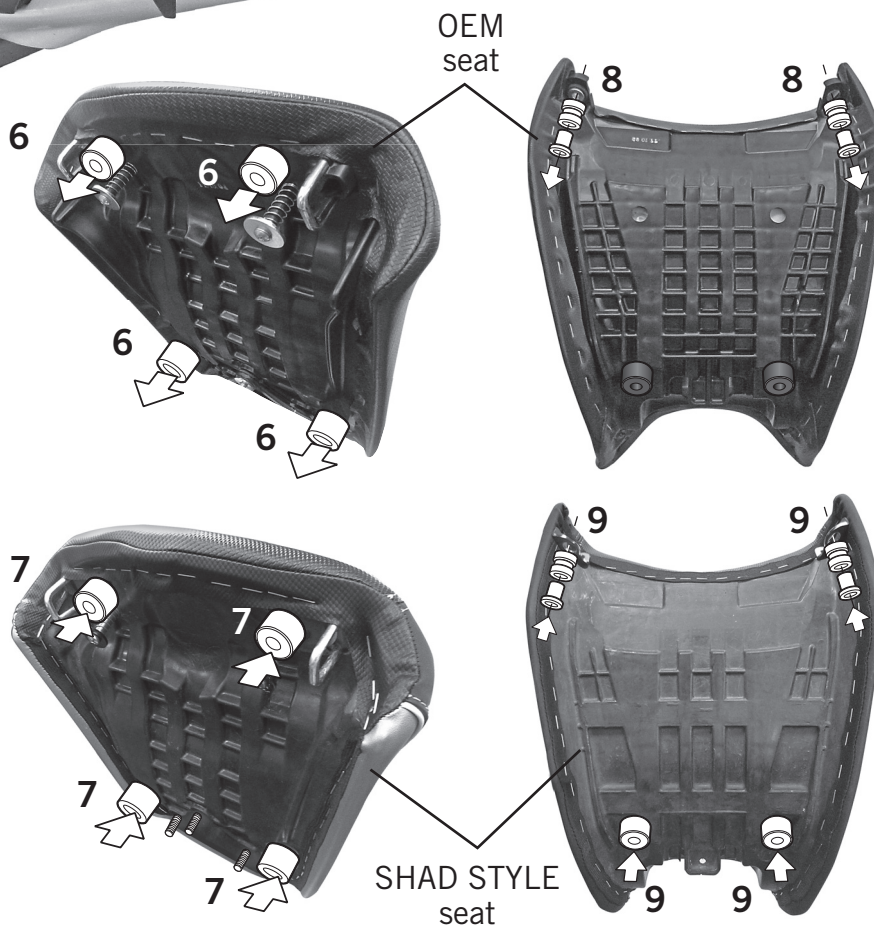

**3.**

- Ⓔ Conectar el cableado suministrado por SHAD según el esquema de conexión. En caso de duda, contactar con su taller o distribuidor habitual.
- ⒼⒸ Connect wiring supplied by SHAD as shown in the connection diagram. Connection to the motorbike should be performed by the customer or garage. If in doubt, contact your usual distributor or garage.
- Ⓕ Connecter le câblage fourni par SHAD conformément au schéma de branchement. La connexion du câblage sur la moto doit être réalisée par le client ou dans un garage. En cas de doute, veuillez contacter votre distributeur ou votre garage habituel.
- Ⓓ Die von SHAD gelieferte Verkabelung gemäß Anschlussdiagramm anschließen. Der Anschluss der Kabel am Motorrad wird in der Werkstatt auf Kosten des Kunden durchgeführt. Bei Fragen, kontaktieren Sie bitte Ihren Vertriebshändler oder Ihre Werkstatt.
- Ⓘ Collegare il cablaggio fornito da SHAD rispettando lo schema di connessione. La connessione del cablaggio della moto sarà responsabilità del cliente o del meccanico. In caso di dubbi, vi invitiamo a contattare il vostro distributore o meccanico abituale.
- Ⓗ Ligar a cablagem fornecida pela SHAD de acordo com o esquema de ligação. A ligação de cablagem na moto é da responsabilidade do cliente ou da oficina. Em caso de dúvidas contacte com o seu distribuidor ou oficina habitual.

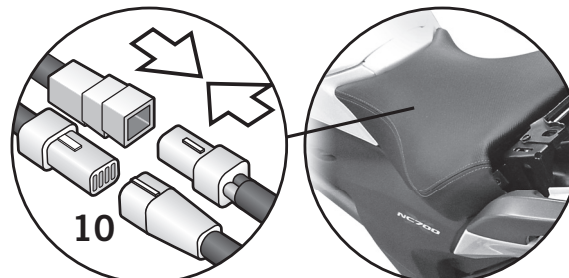

**HONDA NC700X / NC750X HEATED**  
Comfort seat for NC700X (2012- and NC750X (2014-

**SHAD**  
style



15

11

12

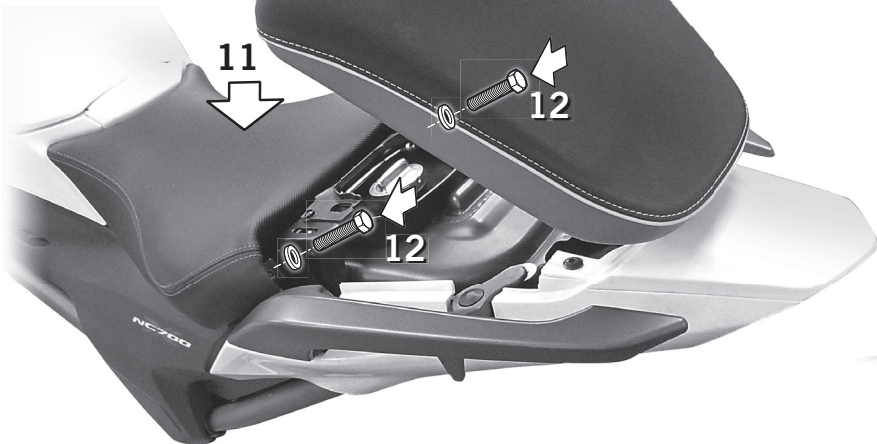

4. (E) Montar los asientos SHAD STYLE

(GB) Fix SHAD STYLE seats

(F) Monter les selles SHAD STYLE

(D) Die SHAD STYLE Sitzbänke montieren

(I) Montare le selle SHAD STYLE

(P) Montar os assentos SHAD STYLE

13

14

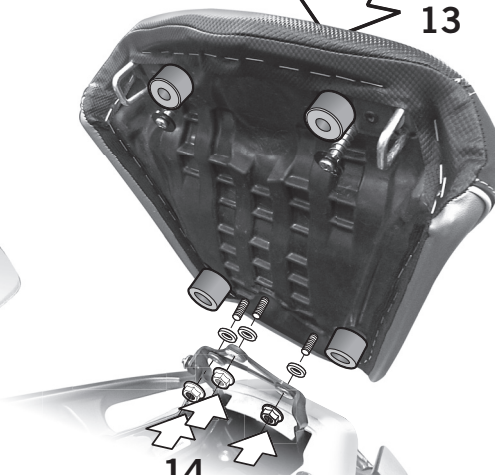

**CONEXIÓN / WIRING / CONNEXION / VERKABELUNG / CONNESSIONE / LIGAÇÃO:**

Opción 1 / Option 1 / Option 1 / Option 1 / Possibilità 1 / Opção 1

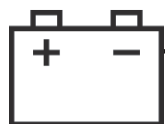

Pasando por la llave - Via the key  
En passant par la clé - Direkt über den Schlüssel  
Passando dalla chiave - Passando pela chave

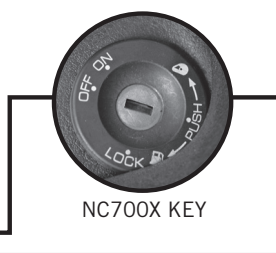
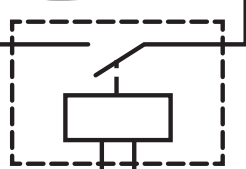

SHAD  
CONSOLE



Opción 2 / Option 2 / Option 2 / Option 2 / Possibilità 2 / Opção 2

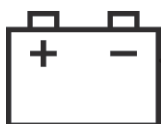

Directo a batería - Direct to the battery - Direct sur la batterie  
Direkte Verkabelung mit der Batterie - Diretto alla batteria - Directo à bateria



**HONDA NC700X / NC750X HEATED**  
Comfort seat for NC700X (2012- and NC750X (2014-

**SHAD**  
*style*

**PROPUESTA DE MONTAJE / SUGGESTED INSTALLATION / RECOMMANDATION DE MONTAGE  
MONTAGEVORSCHLAG / PROPOSTA DI MONTAGGIO / PROPOSTA DE MONTAGEM**



- (E) SHAD recomienda el montaje de la consola en el centro del manillar.
- (GB) SHAD recommends installing the console on the central part of the handlebar.
- (F) SHAD recommande de monter la console au centre du guidon.
- (D) SHAD empfiehlt die Installation der Konsole auf dem zentralen Teil des Lenkers
- (I) SHAD consiglia di montare la piastra nel centro del manubrio.
- (P) SHAD recomenda a montagem do painel no centro do guidador.

**CONSOLA / CONSOLE / CONSOLE / KONSOLE / PIASTRA / PAINEL:**

<p>ENCENDIDO POWER ON ALLUMÉ EINSCHALTEN ACCESO LIGADO</p>	<p>Pulse el botón durante 3 segundos cuando la luz (1) esté apagada. <i>Press button for 3 seconds when the light (1) is off.</i> Appuyer sur le bouton durant 3 secondes lorsque le voyant (1) est éteint. <i>Knopf 3 sekunden drücken; wenn das licht (1) ausgeschaltet ist.</i> Premere il pulsante per 3 secondi quando la luce (1) è spenta. <i>Carregue no botão durante 3 segundos quando a luz (1) está desligada.</i></p>
<p>APAGADO POWER ON ÉTEINT AUSGESCHALTET SPENTO DESLIGADO</p>	<p>Pulse el botón durante 3 segundos cuando la luz (1) esté encendida. <i>Press button for 3 seconds when the light (1) is on.</i> Appuyer sur le bouton durant 3 secondes lorsque le voyant (1) est allumé. <i>Knopf 3 sekunden drücken; wenn das licht (1) eingeschaltet ist.</i> Premere il pulsante per 3 secondi quando la luce (1) è accesa. <i>Carregue no botão durante 3 segundos quando a luz (1) está ligada.</i></p>
<p>POTENCIA BAJA POWER ON FAIBLE PUISSANCE NIEDRIGE TEMPERATUR POTENZA BASSA TEMPERATURA BAIXA</p>	<p>Pulse el botón para cambiar la temperatura (luces 1+2). <i>Press the button to shift heating level (leds 1+2).</i> Appuyer sur le bouton pour modifier la température (voyants 1 + 2). <i>Knopf drücken, um die heizstufe zu ändern (leds 1+2).</i> Premere il pulsante per modificare il livello di riscaldamento (spia 1+2). <i>Carregue no botão para mudar o nível de temperatura (luzes 1+2).</i></p>
<p>POTENCIA ALTA POWER ON HAUTE PUISSANCE HOHE TEMPERATUR POTENZA ALTA TEMPERATURA ALTA</p>	<p>Pulse el botón para cambiar la temperatura (luces 1+3). <i>Press the button to shift heating level (leds 1+3).</i> Appuyer sur le bouton pour modifier la température (voyants 1 + 3). <i>Knopf drücken, um die heizstufe zu ändern (leds 1+3).</i> Premere il pulsante per modificare il livello di riscaldamento (spia 1+3). <i>Carregue no botão para mudar o nível de temperatura (luzes 1+3).</i></p>



<p>STAND BY</p>	<p>Led de encendido parpadeando. Se apaga la calefacción cuando el nivel de batería es bajo. Permanece activo durante 3 minutos antes de apagarse. <i>Power led 1 flashing. Switch off the heating when the battery is low. It remains activated for 3 minutes before switch off.</i> Le bouton d'allumage clignote. Eteignez le chauffage lorsque le niveau de batterie est faible. Il restera allumé durant 3 minutes avant de s'éteindre. <i>Power-led 1 blinkt. Wenn der batteriestand niedrig ist, schaltet sich die heizung aus. Bleibt vor dem ausschalten für 3 minuten eingeschaltet.</i> Spia di potenza 1 lampeggiante. Spegner il riscaldamento quando la batteria è bassa. Rimane attivo per 3 minuti prima di spegnersi. <i>Botão de ligado a piscar. Desligue o aquecimento quando o nível de bateria for baixo. Irá permanecer activo durante 3 minutos antes de desligar.</i></p>
<p>ERROR ERROR ERREUR FEHLER ERRORE ERROR</p>	<p>Todas las luces parpadean. Compruebe la polaridad o las conexiones. <i>All leds flashing. Check the polarity or connections.</i> Tous les voyants clignent. Vérifiez la polarité ou les branchements. <i>Alle leds blinken. Polarität oder anschlüsse prüfen.</i> Tutte le spie lampeggiano. Controllare la polarità o le connessioni. <i>Todas as luzes piscam. Verifique a polaridade ou as ligações.</i></p>

**SHAD**  
www.shad.es

P.O.BOX 154  
Octave Lecante, 2-6  
Pol. Ind. Can Magarola  
08100 MOLLET DEL VALLÈS  
BARCELONA (SPAIN)

Phone: 0034 935 795 860  
Fax: 0034 935 796 945  
Ligne pour la France: 0034 935 795 868  
Linea per la Italia: 0034 935 795 867