

PIASTRA SPECIFICA - SPECIFIC PLATE
 PLATINE SPECIFIQUE - SPEZIFISCHE PLATTE - PLETINA ESPECÍFICA

YAMAHA XT125 R/X 2005

ISTRUZIONI DI MONTAGGIO - MOUNTING INSTRUCTIONS
 INSTRUCTIONS DE MONTAGE - BAUANLEITUNG - INSTRUCCIONES DE MONTAJE

1



Q.TY n.1

2



RONDELLA Ø6mm
 WASHER Ø6mm
 RONDELLE Ø6mm
 SCHEIBE Ø6mm
 ARANDELA Ø6mm

Q.TY n.4

3



VITE TBEI M6x20mm
 SCREW M8x20mm
 VIS M8x20mm
 SCHRAUBE M8x20mm
 TORNILLO M8x20mm

Q.TY n.4

4



**DISTANZIALE Ø20x3
 foro Ø6,5**
 SPACER
 ENTRENZSTUECK
 DISTANZSTUECK
 DISTANCIADOR

Q.TY n.4

5



VITE TCEI M6x25mm
 SCREW M6x25mm
 VIS M6x25mm
 SCHRAUBE M6x25mm
 TORNILLO M6x25mm

Q.TY n.4

6

**PARTICOLARI INCLUSI NEL
 KIT VITERIA DELLA PIASTRA**
 COMPONENTS INCLUDED IN
 THE FITTING KIT OF THE PLATE
 PIÈCES INCLUES DANS LE KIT
 DE VIS DE LA PLATINE
 DIE EINZELNEN TEILE SIND BEI
 MONTAGEKIT DER PLATTE
 ENTHALTEN
 DESPIECES INCLUIDOS EN EL
 KIT DE ANCLAJES DE LA
 PARRILLA

Q.TY n.-



A

ATTENZIONE: CARICO MASSIMO 6Kg
WARNING: MAX LOAD, 6Kg.
ATENCIÓN: CARGA MÁXIMA, 6Kg.
ACHTUNG: MAX, 6Kg.
¡ATENCIÓN!: CARGA MÁXIMA, 6Kg.

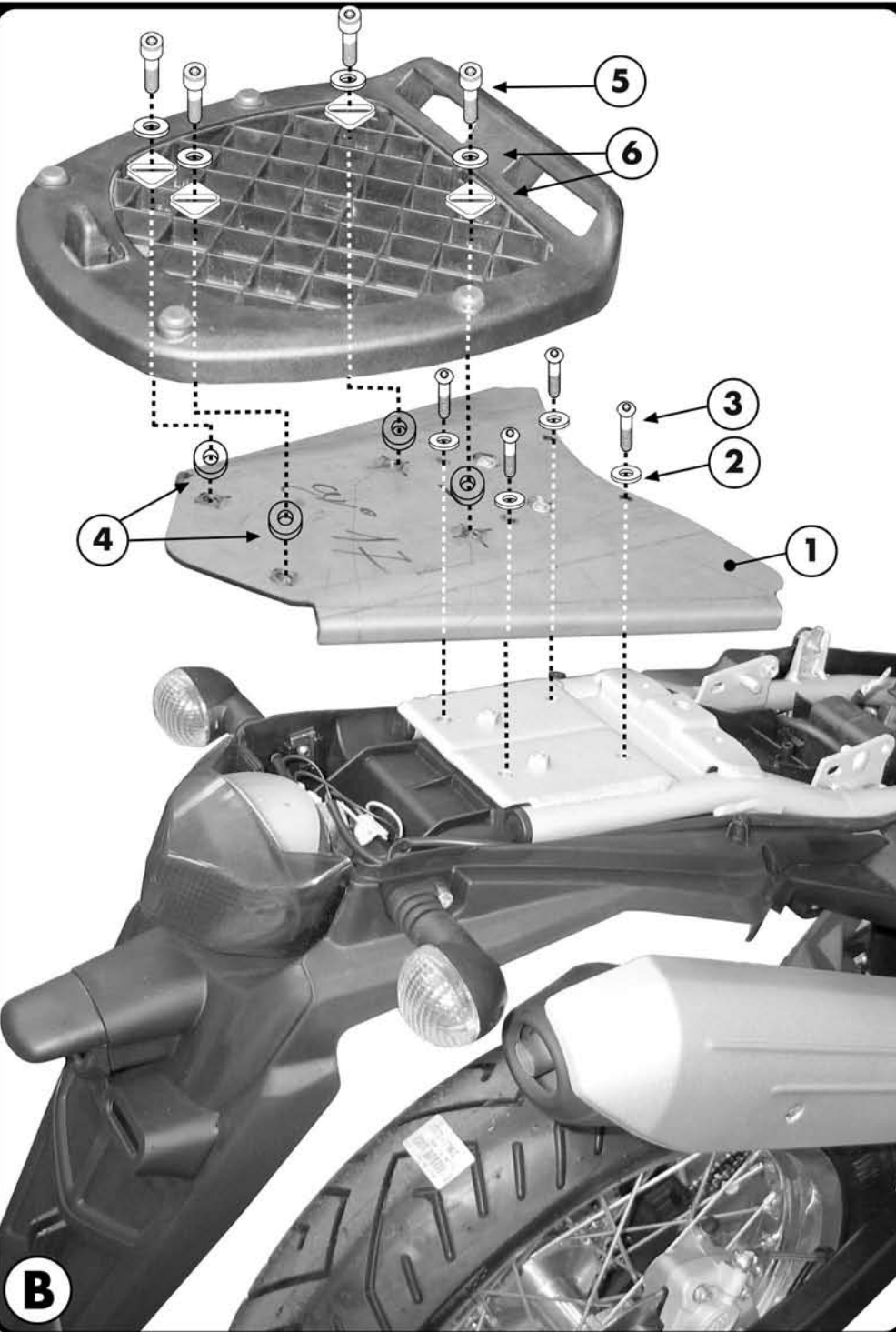

B

PIASTRA SPECIFICA - SPECIFIC PLATE
 PLATINE SPECIFIQUE - SPEZIFISCHE PLATTE - PLETINA ESPECÍFICA

YAMAHA XT125 R/X 2005

ISTRUZIONI DI MONTAGGIO - MOUNTING INSTRUCTIONS
 INSTRUCTIONS DE MONTAGE - BAUANLEITUNG - INSTRUCCIONES DE MONTAJE

I ISTRUZIONI DI MONTAGGIO

- 1) SMONTARE LA CARENATURA ORIGINALE SULLA CODA DELLA MOTO COME INDICATO IN FIGURA A.
- 2) POSIZIONARE LA PIASTRA SPECIFICA COME INDICATO IN FIGURA B.
- 3) ESEGUIRE IL MONTAGGIO PROPOSTO IN FIGURA B.

GB MOUNTING INSTRUCTIONS

- 1) REMOVE THE ORIGINAL REAR FAIRING AS SHOWN IN PICTURE A.
- 2) PLACE THE SPECIFIC PLATE AS SHOWN IN PICTURE B;
- 3) LASTLY PROCEED WITH THE MOUNTING SUGGESTED IN PICTURE B.

F INSTRUCTIONS DE MONTAGE

- 1) DEMONTER LA COQUE ARRIERE DE LA MOTO COMME INDIQUE SUR LA PHOTO A ;
- 2) POISTIONNER LA PLAQUE SPECIFIQUE N°1 COMME INDIQUE SUR LA PHOTO B ;
- 3) FAIRE LE MONTAGE PROPOSE SUR LA PHOTO B.

D BAUANLEITUNG

- 1) ENTFERNEN SIE DIE ORIGINAL HECKVERKLEIDUNG WIE IM BILD A BESCHRIEBEN;
- 2) POSITIONIEREN SIE DIE SPEZIFISCHE PLATTE WIE IM BILD B BESCHRIEBEN;
- 3) ZULETZT GEHEN SIE MIT DER MONTAGE VOM BILD B WEITER.

ES

INSTRUCCIONES DE MONTAJE

- 1) DESMONTAR EL COLÍN ORIGINAL DE LA MOTO COMO INDICA LA FOTO A;
- 2) COLOCAR LA PARILLA ESPECÍFICA COMO INDICA LA FOTO B;
- 3) EJECUTAR EL MONTAJE COMO INDICA LA FOTO B.